

WWW.UNITROL.PL

UNI-TROL
GARAGE EQUIPMENT



USER MANUAL

WHEEL BALANCING MACHINE

MONOLITH



Wheel balancing machine
Monolith

Serial number

Production date

MANUFACTURER

UNI-TROL Sp. z o.o.

ul. Estrady 56, 01-932 Warszawa

tel./fax (22) 834-90-13...14, (22) 817-94-22

NIP 527-020-52-46

SEVICE CENTER

UNI-TROL Sp. z o.o. - SERWIS

ul. Estrady 56, 01-932 Warszawa

tel./fax (22) 834-90-13...14, (22) 817-94-22 **[wew. 134]**

serwis@unitrol.pl

The manufacturer reserves the right to make change to the machine improving its functioning without making corrections in this manual.

CONTENTS

INTRODUCTION.....	4
GENERAL SAFETY REGULATIONS	5
TRANSPORT, STORAGE AND ASSEMBLY	6
DATA PLATE.....	8
TECHNICAL SPECIFICATION.....	9
MACHINE DESCRIPTION.....	10
INSTALLATION.....	12
INSTALLATION REQUIREMENTS.....	12
ELECTRIC SUPPLY REQUIREMENTS.....	12
WORKING AREA REQUIREMENTS.....	13
HOOD INSTALLATION.....	13
MONITOR INSTALLATION.....	13
MACHINE PROGRAM DESCRIPTION.....	14
BALANCING.....	15
MEASUREMENTS.....	16
PROGRAM 3P – HIDDEN WEIGHT.....	17
OPTIMIZATION.....	18
CALIBRATION.....	20
SETTINGS.....	21
SERVICE SCREEN MEASUREMENTS.....	24
DISPLAYING TESTS.....	24
HOOD CALIBRATION AND TESTS.....	24
SENSORS TESTS.....	25
CALIBRATION DEVICE PARAMETERS.....	25
PIEZOELECTRICAL SENSORS TESTS.....	25
MEASUREMENT LOOP.....	25
CAUSES AND REMOVAL OF FAULTS.....	26
SCRAPPING.....	26
CONFORMITY DECLARATION.....	27

INTRODUCTION

Dear Customers,

This manual is intended to familiarize the operator with the most important principles of use, safe operation and maintenance of the wheel balancer Monolith.

Lifting, transport, unpacking, assembly, installation, initial adjustment and testing, maintenance, technical inspections do not require the service presence but must be done with particular caution. The manufacturer accepts no liability for injuries to persons or damage to vehicles or other objects if any of the above-mentioned operations are not carried out in accordance with the operating instructions or if the machine is used incorrectly.

The manufacturer reserves the right to make at any time any changes, material and construction upgrades in order to update the machine and increase its durability and functionality.

The company "UNI-TROL" is responsible for the information provided in this manual. In case of any technical or editorial errors, they will be corrected in subsequent editions.

This publication may not be copied in any part without the manufacturer's authorization.

GENERAL SAFETY REGULATIONS.

Failure to follow the instructions and working methods given in this manual and to ignore warnings may result in serious injury to the operator and other persons. Do not turn on the machine before reading this manual thoroughly and all information contained in it regarding safe work.

The machine may only be operated by qualified and authorized personnel. A qualified operator is a person who has read this manual thoroughly, has undergone appropriate training and has knowledge about machine's safe functioning and adjustment. It is forbidden to operate the machine anyone who are under the influence of alcohol or drugs that impair their physical or mental abilities. However, if the prescribing physician does not see any contraindications, the operator may operate the device.

The following conditions must be fulfilled:

- The operator must be able to read and understand all information from this manual.
- The operator must have full knowledge about machine's functioning and characteristics.
- Unauthorized persons should keep a safe distance from the working machine.
- The machine must be installed according to applicable regulations and standards.
- All persons operating the machine must be properly trained, must follow the correct working methods and must be properly supervised at work.
- Do not leave nuts, screws, tools or other objects on the machine as they may get between the moving parts while the machine is in operation.
- Do not touch electrical wiring, the inside of motors or other electrical equipment unless the power supply has been turned off.
- Read this manual carefully to ensure correct and safe functioning of the machine.
- The manual should be kept in near the machine, in a place accessible to the operator, to enable checking of information or clarification of doubts regarding its functioning.
- Fulfill the general rules for the industrial accidents prevention for high voltage equipment during maintenance.
- Any modifications made without authorization release the manufacturer from liability in case of damage or accident. Particularly this applies to dismantling or tampering with the safeguards used in the machine.

ATTENTION !

Do not remove safety information plates or plates informing about operating methods from the machine. Immediately attach or replace missing or illegible warning and information plate. Replacement plates can be obtained at the manufacturer .

TRANSPORT, STORAGE AND ASSEMBLY

TRANSPORT

After arriving at the destination, check that it has not been damaged during transport. Check the delivery completeness according to the transport documents. In case of any lack in delivery or transport damage, the responsible person or the carrier must be informed immediately. Be careful and considerate when loading.

ATTENTION !

All activities related to packing, lifting, moving, transporting and unpacking must be carried out only by qualified personnel.

Warunki transportowania urządzenia

The balancing machine is sent as a complete piece of equipment (quick change holder, balancing machine, protective hood, operating manual). The balancing machine can be packed in a few different ways:

- pallet + stretch foil + carton box
- pallet + stretch foil
- pallet + carton box
- stretch foil

The machine should be transported in its original package and stored in position marked on the outer packaging.

Dimensions in package:

Occupied surface:	1000x1000 mm
Height:	1000 mm
Weight:	100 kg

Transport and storage temperature: -25°C - +55°C.

STORAGE

The machine should be stored in a dry room free of dust. Do not store other objects on the machine package. It may damage the machine.

ASSEMBLY

Take special care when unpacking, assembling and preparing the device for work. Failure to follow the operating procedures listed here may result in damage to the machine and injuries to the operator and other persons.

Remove the upper part of the packaging and check that the machine has not been damaged during transport. In order to move the machine, insert the forklift forks into the slots on the pallet on which the machine is positioned. The location of the device must strictly meet the requirements of work safety regulations. Do not move the machine connected to the electrical and pneumatic systems.

Environmental conditions for the machine workplace:

- Humidity 30% - 95%
- Temperature 0°C - 55°C

ATTENTION !

The device may not be used in potentially explosive atmospheres.

DATA PLATE

When contacting the service provide the balancer model and serial number. This will facilitate the help of our technical staff.

The machine data is presented on the Figure 1. If there is incompatibility between the data in this manual and the data on the machine data plate the data on the data plate are valid.



 <p>www.unitrol.pl</p>	<p>Uni-trol Sp. z o.o. ul. Estrady 56, 01-932 Warszawa Zakład Produkcyjny - Serwis - -Salon Sprzedaży ☎/ 📠 +48 22 8179422 e-mail: office@unitrol.pl</p>	
<p>Wheel balancer MONOLITH</p>		
<p>Technical data :</p> <ul style="list-style-type: none"> - power supply : 230 V / 50 Hz - pneumatic supply : 8 - 10 bar - motor : 80 W - noise level : < 67 dB - average noise level : < 65 dBA - weight netto : 85 kg 		
<p>Serial number:</p> <p style="text-align: center;">138/10</p>		
<p>Made in Poland</p>		

Fig. 1.

TECHNICAL SPECIFICATION

Wheel diameter	10"-30"
Wheel width	2"-15"
Imbalance accuracy	1g
Imbalance position accuracy	0,9°
Measuring time	7s
Max. wheel weight	60kg
Motor	80W
Spindle rotating speed	160 rpm
Wheel balancer dimensions	
Without hood, without monitor, with wheel adapter	1000 x 580 x 900 mm
With monitor, with open hood	1170 x 850 x 1260 mm
With monitor, with open hood	1170 x 1000 x 1450 mm
Wheel balancer weight	85 kg
Power supply	230V/50Hz
Average noise level L_{SR}	65 dBA

MACHINE DESCRIPTION

Wheel balancer MONOLITH are designed for balancing of car and motorcycle wheels in a single measurement cycle. Original construction solutions assure safe, simple and comfortable operating of the machine as well as reliability and fast wheel balancing.

Wheel balancer components :

- main module in a housing with a cover and an accessory set
- hood
- LCD touch-screen monitor
- quick-mounted adapter
- laser printer (option)

Wheel balancer features:

- modern measuring system with computer data processing technique ensuring high measurement accuracy and speed
- operates any wheels, also light alloy wheels, using all types of weights (both clip on and stick on)
- balancing accuracy setting according to the wheel quality and weight
- easy data input and measurement thanks to camera and touch-screen monitor
- cooperation with special adapters enables efficient fixing for the majority of manufactured wheels
- calibration system allows the user to adjust the machine's measurement system in case of suspicions of improper unbalance location and value
- interface and operations can be adapted to the user's needs and personal preferences
- „hidden weight”
- optimization
- voice synthesizer

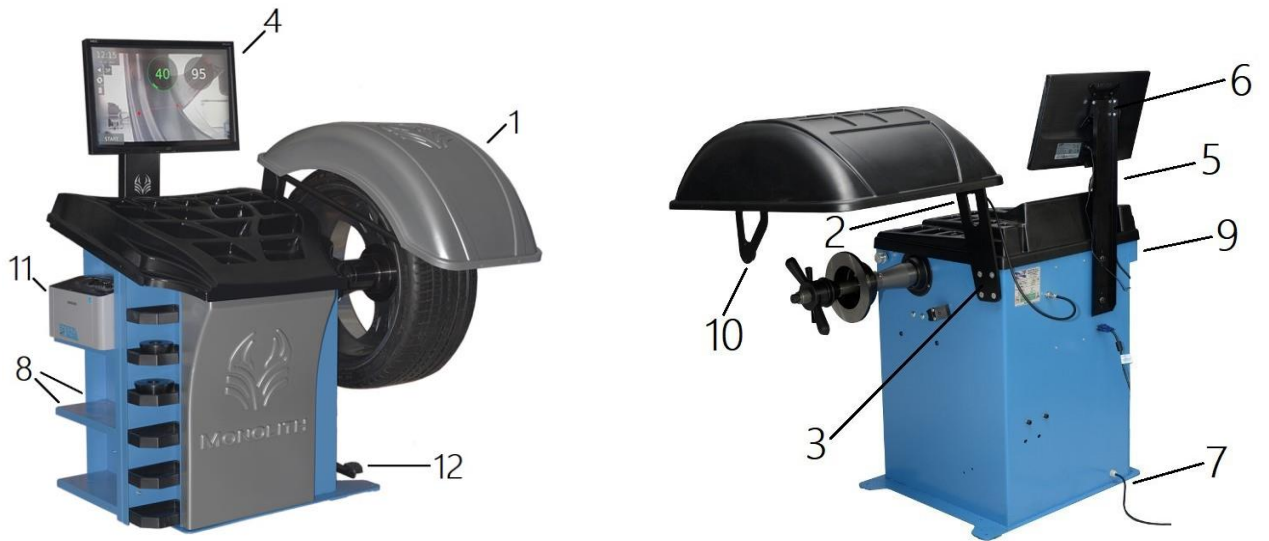

Fig. 2. Balancer's main components.

- 1 – hood
- 2 – hood holder
- 3 – hood axle shoulder
- 4 - monitor
- 5 – monitor bracket
- 6 – monitor tilting bracket
- 7 – power cable exit
- 8 – shelves
- 9 – main switch
- 10 – USG sensor
- 11 – laserow printer
- 12 – pneumatic clamp pedal

INSTALLATION

The following operations can be carried out by persons who have been trained in machine servicing and operating. Follow the instructions below carefully in order to prevent machine's damage or injury risk. Make sure that no persons are in the working area.

INSTALLATION REQUIREMENTS

The balancer should be installed at a safe distance from walls, columns and other machines. The room must be equipped with an electric power source. The balancer may be placed on any surface provided it is dry, even and hard. All parts must be uniformly illuminated with light of an intensity ensuring safe execution of all adjustment and maintenance activities mentioned in the manual. Shadows, light reflections and blinding light are unacceptable. All situations that could cause eye strain should be avoided. Lighting must be installed in accordance with the regulations at the place of installation.

Before installation, unpack all parts and check whether they have not been damaged. Issues related to maneuvering and lifting are discussed in the chapter "Transport, storage and assembly".

ATTENTION !

**Do not screw the balancer to the ground!
The holes in the casing bottom are for transport purposes only!**

ELECTRIC SUPPLY REQUIREMENTS

The balancing machine is powered from 230V 50Hz single-phase alternating current. The machine should be connected to the power supply by means of appropriate plug and socket used in the place of installation and protected by a 30mA residual current fuse. The machine current consumption is structurally secured by a 2A long-blow fuse.

INSTALLATION PLACE

The balancer should be installed in a closed, dry and heated in autumn and winter room. The relative air humidity should be 30-95% without condensation, and ambient temperature 0-55 ° C. The base for machine foundation should be hard, solid and flat (preferably concrete). The balancer should be placed on three rubber pads which are delivered with machine. The pads should be placed under flat feet welded to the machine base.

WORKING AREA REQUIREMENTS

The dimensions of the balancer determine its working area. Only trained and authorized persons may be present in this area. The area requirements for the machine, presented on fig.3.1. are 2870x3000 mm. 1 and 2 operators working places.

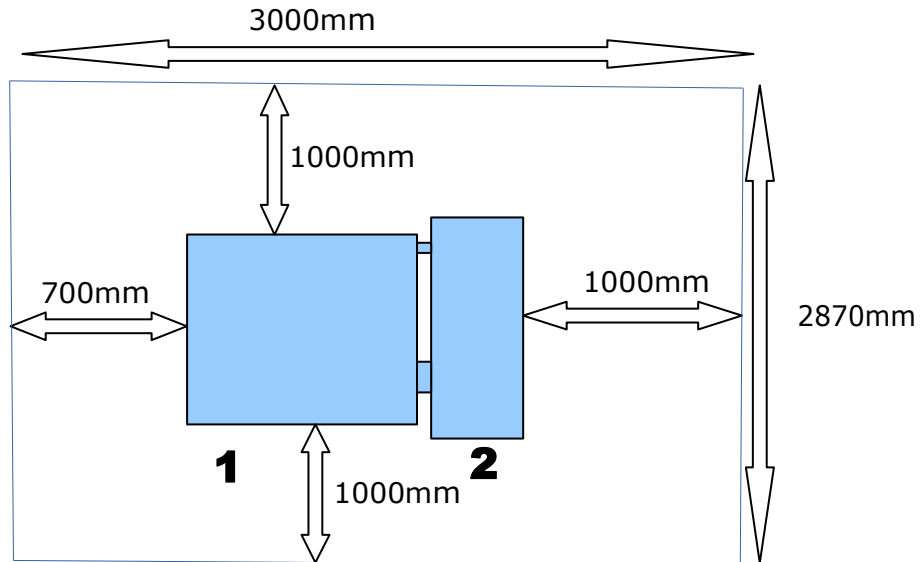

Fig. 3 Machine are requirements.

HOOD INSTALLATION

See fig. 2.

- Unscrew the bolts from hood axle shoulder (3),
- Holding the hood (1) place it in a position so hood holder holes (2) coincide with shoulder holes (3),
- screw hood holder (2) to shoulder (3).

MONITOR INSTALLATION

See fig. 2. Screw monitor bracket (5) to machine casing with 2 bolts with large pads. Place monitor tilting bracket (6) then screw the monitor (4). Connect the power cable, signal cable and USB cable to monitor.

MACHINE PROGRAM DESCRIPTION

The balancing machine operation is controlled by the program, or rather a set of programs, which is activated after the power is turned on. Press the button (Fig. 2 (9)) on the housing back to start the machine. If the voltage is on the network, the button will be illuminated and then the machine program will start. In the initial phase the dots will be displayed on the monitor to indicate the start and testing of the system. After several seconds, the initial screen of the program will be displayed on the monitor. The initial screen will display the available program options as well as the current date and time.

Balancer Monolith is equipped with touch screen, so the program choice action is made by touching the appropriate place on the monitor screen. From the initial screen you can choose the following actions:



Fig. 4 Initial screen

- a. balancing
- b. optimization
- c. calibration
- d. programme settings and testing
- e. switch off program

To turn the machine off, first touch on the initial screen a rectangle with the icon of the switch, wait a few seconds to close the system, then turn off the electric button (Fig. 2 (9)) located on the machine's casing.

BALANCING

To pass to this function touch the rectangle with the unbalance icon and the signed "Balancing". Camera image with the fragment of the wheel placed on the holder will appear on the screen. On the left side of the screen there will be active areas that trigger the appropriate program actions.

For the purpose of this manual the active areas of the touch screen will be called buttons.

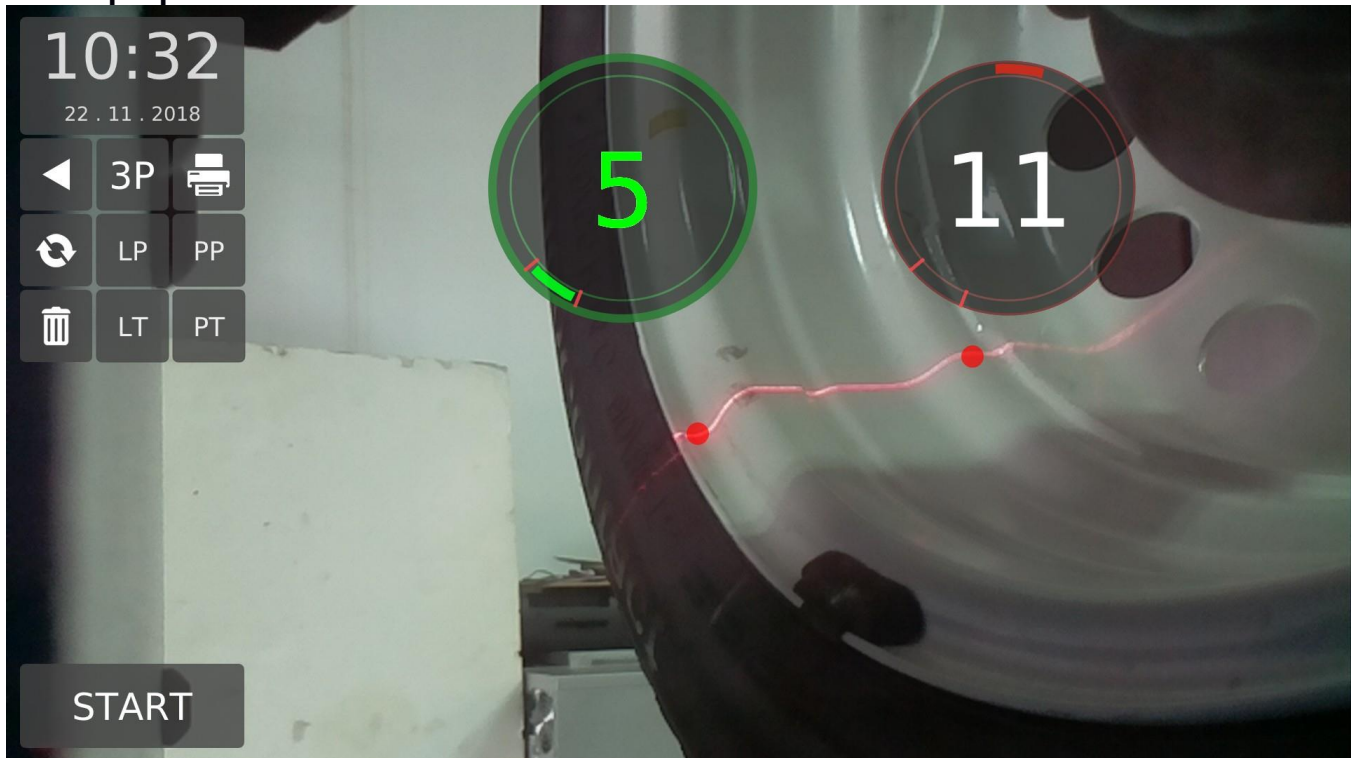

Fig. 5 Balancing screen

On the left side of the screen, at the top, there is a clock area and at the bottom a button for starting and stopping the measurement. Below the clock area there is a set of buttons with the following functions:

1. RETURN – return to initial program screen
2. REFRESH - displaying the balancing result again
3. CLEAN – cancel previously defined weights points
4. PRINT – start balancing results printing
5. LP - assigning the last measurement to the left front wheel
6. PP - assigning the last measurement to the right front wheel
7. LT - assigning the last measurement to the left rear wheel
8. PT - assigning the last measurement to the right rear wheel
9. 3P - program 3P will appear when both weights points are inside the rim

MEASUREMENTS

The measurement is initiated with the START button. A wheel mounted in the holder begins to rotate and, if compressed air is connected to the machine, the hood automatically closes. When hood is closing the ultrasound sensor measures the distance to the edge of the wheel rim. During acceleration you may indicate on the image of the rotating wheel the points for balancing weights.

After the wheel has reached the measuring speed, the machine makes measurement, after which the hood is opened and the wheel is braked. The wheel will stop at the external point of the calculated unbalance. If the external unbalance is zero, the wheel stops at the internal unbalance point.

The measurements results are displayed in two circles, on which circumferences move the rectangles symbolizing the balancing weights positions. If weights points haven't been entered during the measurement interrogation points will be displayed in the circles instead of numbers. Then press the "Refresh" button, enter the point (s) and press "Refresh" again. Rectangles symbolizing the weights positions move around the circumference while turning the wheel. As you rotate, the rectangles color changes from green in unbalance place to red in the opposite position. In addition, if the rectangle is in the segment marked with two lines, the outer circle will be bolded and an acoustic signal will appear. This means that the wheel has been set in the position for placing the balancing weight. And so, if the segment marked with two lines is in the top circle, we place the weight at 12 o'clock, if the segment is located at the bottom, on the left side of the circle, we place the weight on the laser line. Setting the wheel to the unbalance position can be done manually or automatically by touching on the screen the area in which the unbalance value is shown.

Weights points are entered by pointing them on the screen, on the displayed laser line. The laser line lights up at the start of measurement or after pressing the "Refresh" button. If we enter only one point on the laser line the program will accept it as the internal weight point while the external point will be calculated based on the ultrasound sensor measurement. Attention, if the ultrasound is incorrect, after the wheel is braked, "USG 0" will appear in the result boxes. In this case, repeat the ultrasound measurement - make sure that the hood is fully open and then press START again.

If we enter two weights points on the screen both weights will be placed inside the rim, the inner weight can either be studded or glued. The weight position is indicated by the segment on the unbalance result circle. The position of this segment can be changed by indicating on the screen the upper part of the result circle (at 12 o'clock) or the lower part (at the laser line).

Points already entered can be moved to indicate other ones in their vicinity. You can also drag it to a different position without detaching from the screen,.

Correctly indicated points are valid until they are redefined. This means that each next mounted wheel, after pressing START, will take the previous defined points. The same applies to ultrasound measurements. It remains in effect until "Clear" is indicated.

PROGRAM 3P – HIDDEN WEIGHT

When the inner weight is defined inside the rim and we want to hide it behind the spoke we can split it in two weights which will be placed on both sides in places not visible from the outside (behind the spokes)

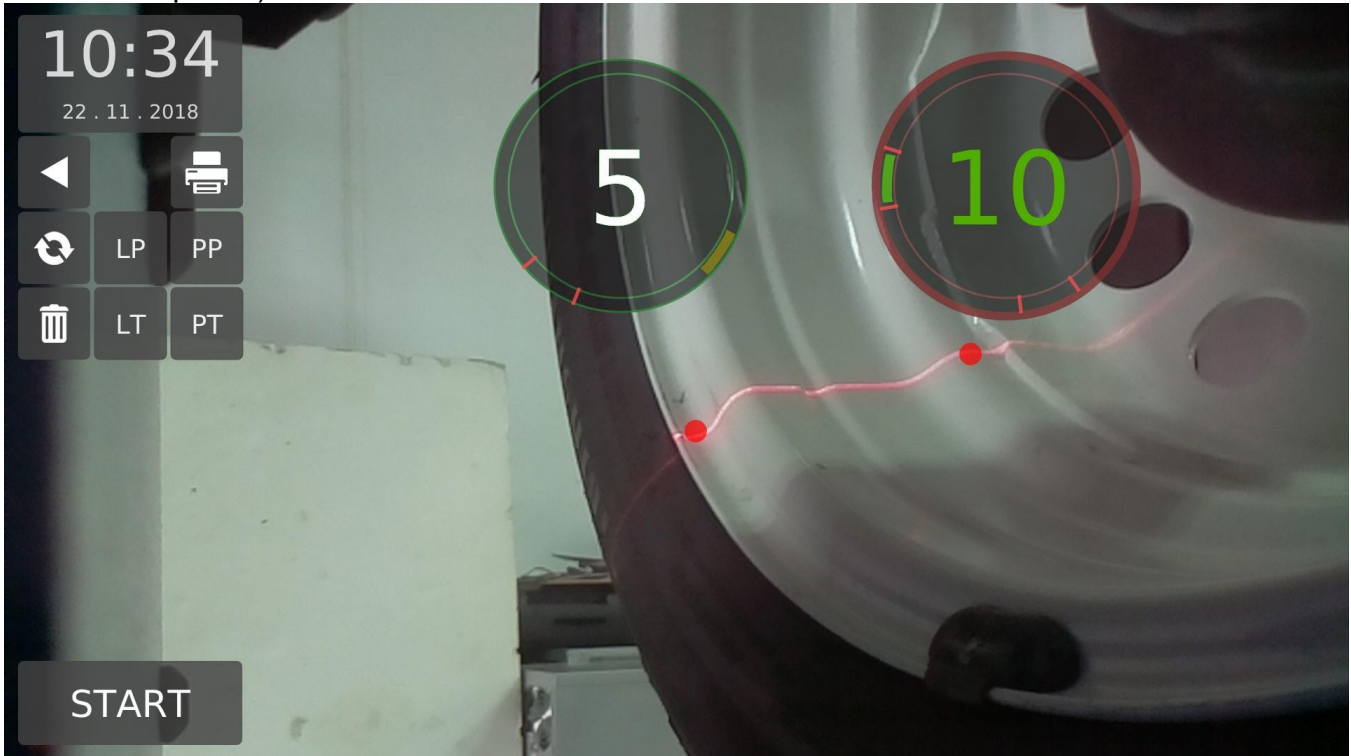

Fig. 16 Active „Hidden Weight” function

The action of splitting weight on two parts is initiated with the "3P" button which always appears when the external weight is defined inside the rim. By pressing "3P" it changes into "3P1" which will be used to define the first hidden weight. Before you press it, you must manually set the wheel to a convenient position. After defining the first point "3P1" will change to "3P2". Then set the wheel to the second convenient position and press "3P2". After defining both points the "3P2" button disappears and in the result circle for the external weight appears:

- in weight position (3P1 or 3P2) - weight value (green color, enlarged outer circle, acoustic signal)
- outside the weight position - the inscription "3P".

The points 3P1 and 3P2 range is around +, - 30 degrees. The laser line lights in this range when these points are being defined. In the "3P" program an information field describing the next steps to be carried out appears over the START button.

Double-click "Refresh" button to return to the stage before 3P points have been defined.

OPTIMIZATION

To move to this function choose the rectangle with the optimization icon signed "Optimization". On the screen background the camera image with wheel fragment will be seen. On the left side of the screen there will be active areas and buttons that call up the appropriate program actions. And just like in the measurement of unbalances, we have: clock at the top, START button at the bottom.

Below the clock there are buttons "Return", "Refresh" and "Clear" and under them an information field describing the next steps in optimizing process.

The active buttons in this screen have the following action:

1. RETURN – return to initial program screen
2. REFRESH – start new optimization cycle with previously entered point on a rim and previous USG measurement
3. CLEAN – stop optimization cycle and/or start new one with previously entered point on a rim and previous USG measurement cleaned

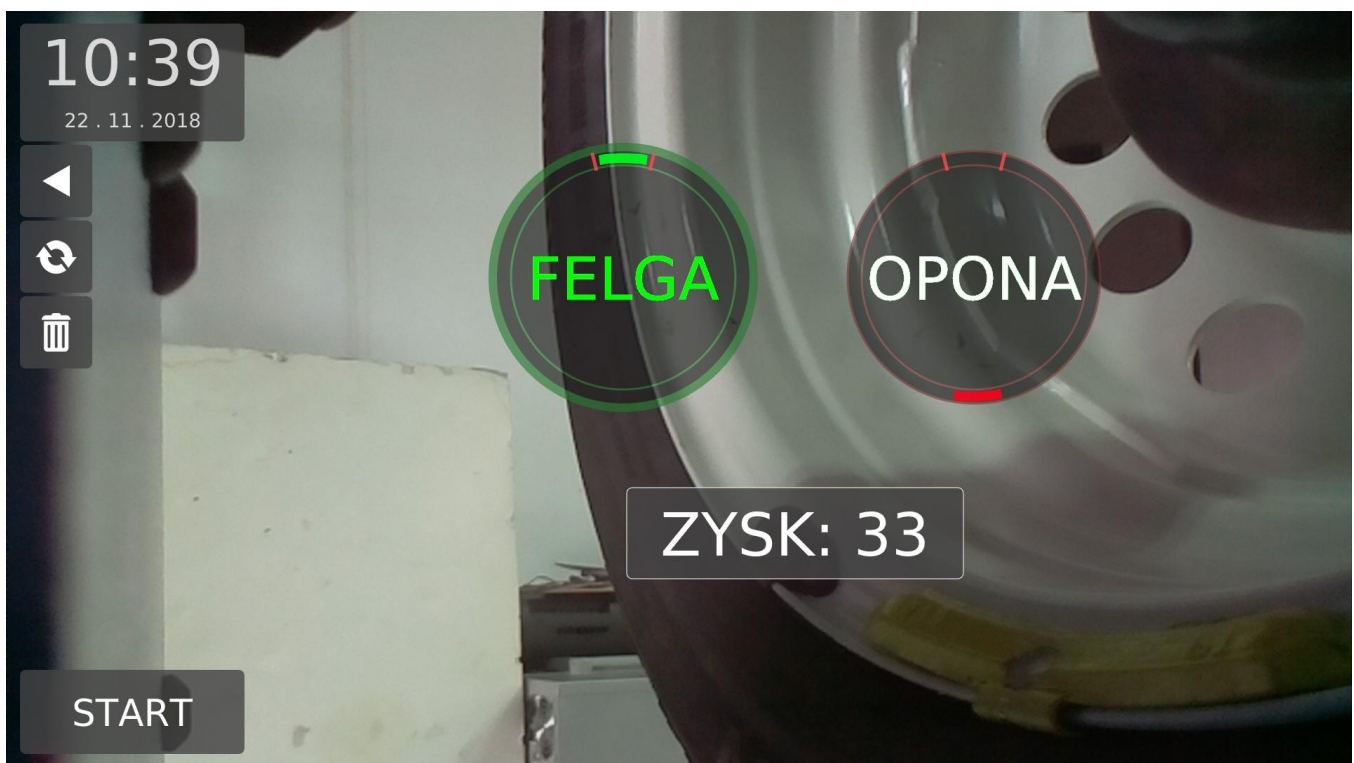

Fig. 17 Optimization screen

The optimization starts with the rim unbalance measurement. The rim without tyre (first measurement course) and the rim with tyre (second measurement course) should be mounted on the holder the same way. Then we point on the screen a point on the rim inner edge and select START. For optimization the program assumes the width of the rim determined from the indicated point and from the ultrasound measurement made during closing of the hood. To optimize just enter one point inside the rim.

If after rim measuring "USG 0" appears on the result circles, press "Clear", open the hood and repeat the rim measuring procedure.

MONOLITH

After the measurement, the program will display a rim unbalance result. Next, put the tyre on the rim and place the wheel on the balancer, remembering its orientation relatively to the holder. Now, without entering points, press START and the program will measure whole wheel unbalance. The optimization result will be the profit in grams which will be obtained after turning the tyre relative to the rim by the angle given in the "RIM" and "TIRE" wheels shown on the screen. After ripping the rim with the tyre we carry out a standard wheel unbalance measurement.

If, when measuring the rim itself, it turns out that the rim is balanced further optimization makes no sense and you can stop the process at this point.

CALIBRATION

Move to calibration screen by selecting the rectangle with the calibration icon signed "Calibration". In this program we can calibrate the machine parameters responsible for the correct imbalance calculation in two ways. Either using a special device (MEL) attached to the machine or with a balanced wheel with a calibration weight attached outside. For a car the calibration weight value is 80g.

After entering the calibration screen we will see, similarly to the previous screens, the clock at the top and the START button at the bottom. Below the clock there are buttons "Return", "Calibration with MEL", "Calibration with wheel", "Refresh" and "Clear". Below them there is an information field. In case of calibration with wheel the screen background is the camera image with fragment of the wheel. In case of calibration with device a graphic shows the balancer handle with the mounted on it device.



Fig. 18 Calibration screen

The active buttons in this screen have the following action:

1. RETURN – return to initial program screen
2. Calibration MEL – calibration with device
3. Calibration with wheel – calibration with wheel
4. REFRESH - start new calibration cycle with previously entered point on a rim and previous USG measurement
5. CLEAN - stop calibration cycle and/or start new one with previously entered point on a rim and previous USG measurement cleaned

Touch START to start calibration. At the end the wheel is stopped, the hood is opened and the display shows whether the calibration result is correct or not.

SETTINGS

From the "Settings" screen you can change language, message volume, unbalance accuracy, check program version, go to service mode with access to internal parameters and functions for testing individual machine's components.

The settings are entered from the initial screen after touching the rectangle "Settings". There are following options:

1. Sound
2. Balancing
3. USG
4. Print
5. Clock
6. Others
7. Service

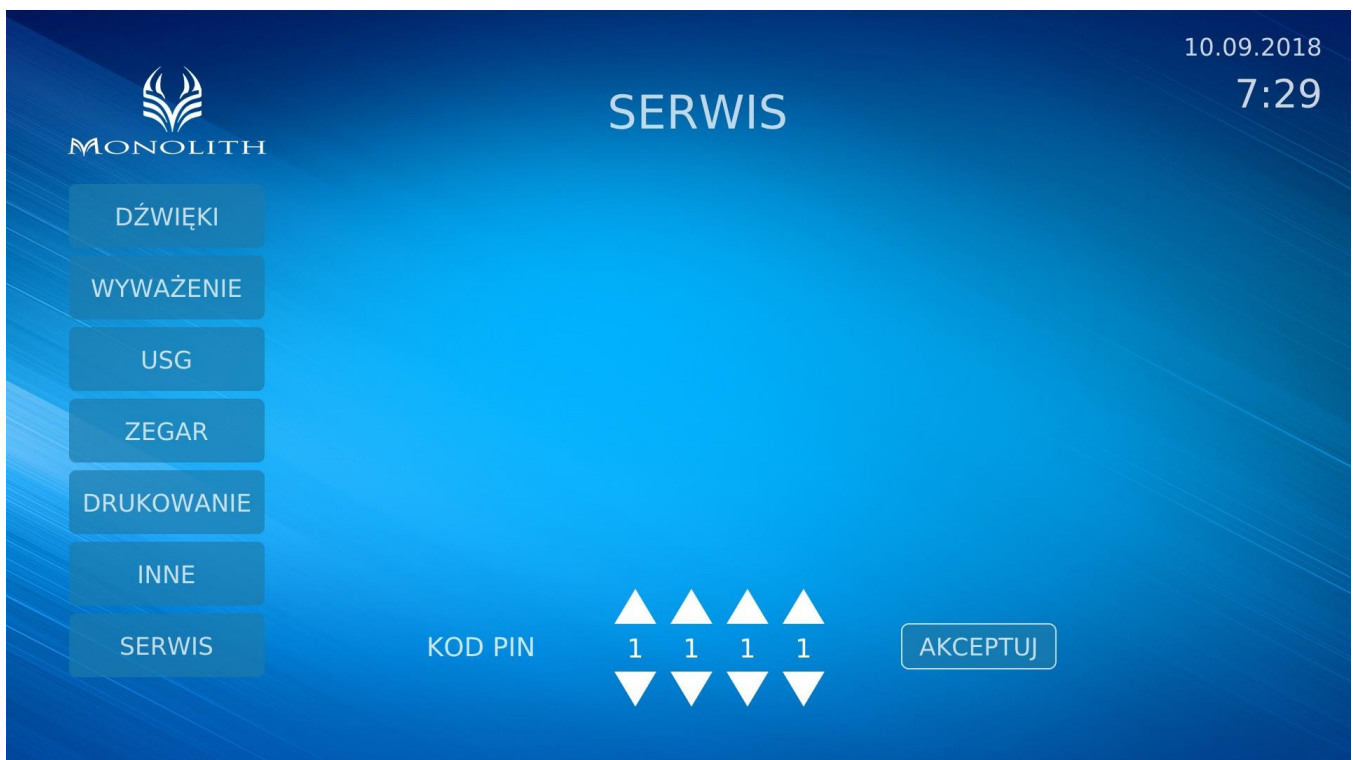

Fig. 19 Settings screen

SOUND

This options group allows to set the machine sounds volume and to enable / disable lector's messages. If the lector is turned off the machine only sounds signaling.

BALANCING

Here we define the threshold from which the balancer treats the measurement result as being greater than zero. Defined thresholds are 2g, 5g and 10g. In this options set we also set the rounding of the measurement result: up to 1g or up to 5g.

USG

Here we enable or disable the possibility of automatic width measurement with USG sensor. When the automatic measurement is turned off the wheel width must be entered manually in millimeters. The field for entering the width will appear on the screen after switching off the automatic measurements.

CLOCK

The machine has a built-in real-time clock supported by batteries. Normally the clock works and maintains the correct date and time even after the power is turned off. If the set date and time were different from the actual ones you can set the desired values with this option. From now on, as long as the backup battery is operational, the clock will remember the new date and time set.

PRINT

Here we turn the printer on or off and give the data that will appear on the printout. If the printer is on the buttons for assigning imbalances to the appropriate circles and initiating the report printout will appear on the unbalance measurement screen.

OTHERS

Here we select the text language displayed by the program and voice messages. We also have the balancer's software version number.

SERVICE

After selection of this option the program will ask for a 4-digit code. If the code is correct the service screen goes to. You can enter the service screen from the user level or from the service level. The entry code for the user level is: 1111. In the user mode the values of the relevant machine calibration parameters can be displayed on the screen and a series of tests can be called to check the operation of individual components.

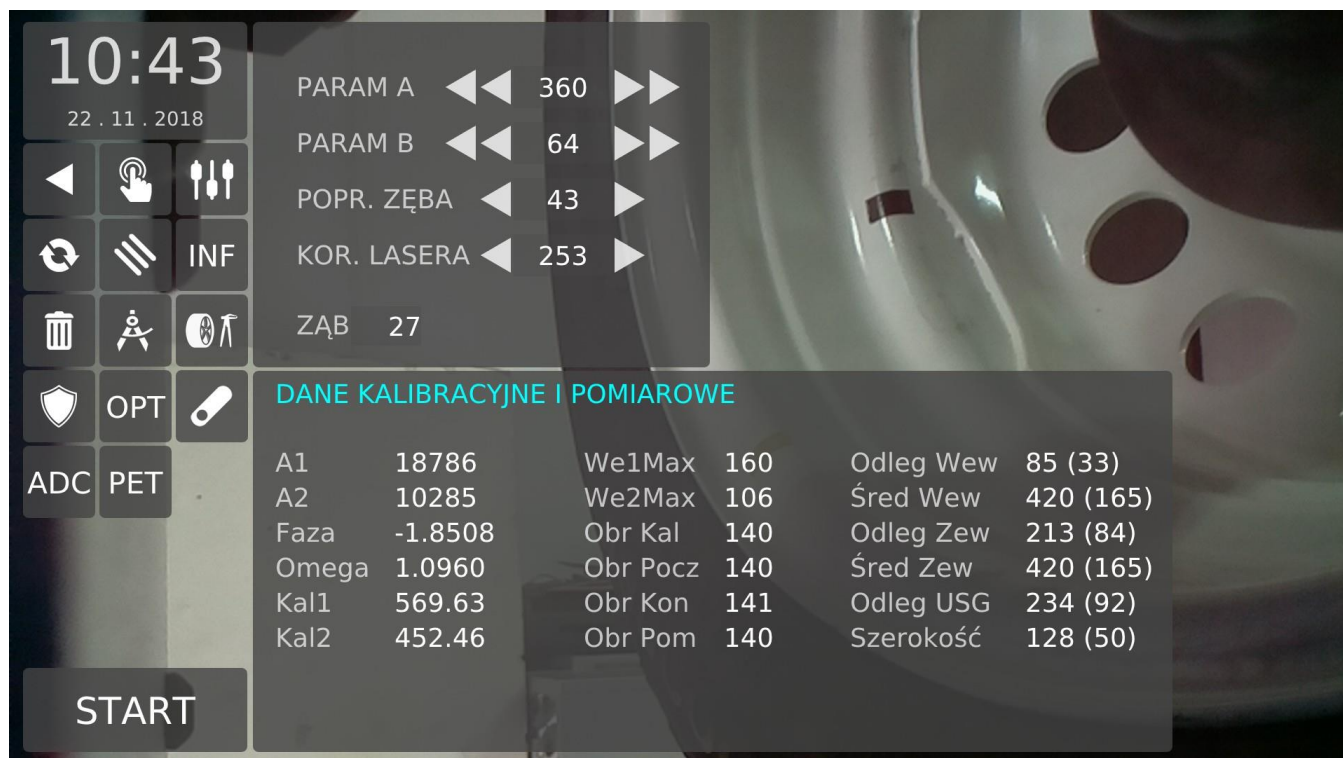

Fig. 20 Service screen

The service entrance code is hidden and allows access to the service screen with full access to parameter changes and component calibration.

Service screen buttons:

Buttons are marked (line, column)

(1,1) – return to SETTINGS screen

(2,1) – refresh balancing results

(3,1) – clear the entered points and USG measurement, hide tests

(2,1) – touch screen calibration (inactive for user)

(2,2) – camera calibration (inactive for user)

(2,3) – balancer drive calibration (with wheel or MEL device) (inactive for user)

(3,1) - displaying the balancer parameters and buttons for calling the tests

(3,2) - displaying information about the current measurement: balancing measurement data, wheel geometric data accepted for calculation

(3,3) – start measurement

Test buttons (displayed after (3,1) pressed:

(4,1) – hood test and calibration

(5,1) – sensors signals tests

(4,2) – wheel sensors tests

(5,2) – start measurement loop

(4,3) – MEL device parameters setting (inactive for user)

SERVICE SCREEN MEASUREMENTS

To start the measurement in the service screen first identify at least one point on the wheel rim. The values of x (the point distance from the machine's casing + approx. 30mm) and y (the diameter of the circle indicated by the point in millimeters) will be displayed above the indicated point. If we give only one point inside the rim the second one will be calculated based on the USG measurement made when closing the hood.

Attention: in service mode the hood is closed only once when the ultrasound distance has not yet been measured. Each next measurement no longer causes hood actions unless the button was pressed beforehand (3,1)- clean.

If the automatic width measurement is turned off, the manually entered width will be used to measure the unbalance.

The measurement starts after selecting the START button. The measurements results in the service mode are rounded up to tenths of a gram and THRESHOLD and ROTATION parameters specified in the machine settings are not applicable here.

SERVICE SCREEN DRIVE CALIBRATION

We enter the calibration screen from the service screen by selecting the button (2,3). After calibration, which was called from the service mode, the calibration parameters and information about the error code are additionally displayed. The zero code means correct calibration.

DISPLAYING TESTS

After pressing the button (3.1) additional buttons will be displayed on the left side of the screen. They enable testing of selected components of the balancer: hood calibration and test, optocouplers test, calibration instrument settings, piezoelectric sensors test and measuring loop.

HOOD CALIBRATION AND TEST

After selecting CALIBRATION AND PROTECTION TESTS window close the hood (manually or by means of cylinder) and select START button. Then open hood completely and select START again. After a while the message HOOD CALIBRATION COMPLETED will appear in the window. If the calibration is correct the hood will work automatically. USG correction can be set in the window as well in order to obtain the desired width during wheel geometry measuring. The USG correction is in millimeters. The window also displays the following measurements: the distance of the ultrasound and the hood potentiometer value enabling to check these components operation.

SENSORS TEST

After the window WHEEL SENSORS TEST displayed the test is started with START button. The wheel starts to rotate and two values will appear every two revolutions in the window: FILLING and OFFSET. The test is performed cyclically until you select STOP.

CALIBRATION DEVICE PARAMETERS

In this window MEL calibration device's geometrical parameters are shown. These parameters are set at the machine production stage in the balancing process.

PIEZOELECTRICAL SENSORS TEST

This window displays ADC readings from the piezoelectric sensors. Each of the two sensors: right and left is read in two ADC channels: ordinary and amplified.

MEASUREMENT LOOP

This test enables measurements cyclic switching. The time between consecutive measurements is set at intervals of 15 seconds. The test is used, for example, after replacing balancer drive components.

CAUSES AND REMOVAL OF FAULTS

FAULT	POSSIBLE CAUSES	FAULT REMOVAL
After starting the machine switch does not light up, monitor does not display anything.	No power, electrical system damage.	Check the fuse and all electrical connections.
Hood does not close / open	No compressed air in the installation.	Check whether compressor switched on and operates correctly.
Hood Improper operation.	Wrong calibration.	Calibrate hood according to the chapter "Hood Calibration and tests".
Wrong indications at different wheel fixings.	Wrong centering, dirty cone and/or spindle, worn centering cone, damaged nut, damaged handle (impacted).	Change the centering method, clean the soiled parts, replace the cone, replace the nut, replace the handle.

Contact with our service is always recommended.

SCRAPPING

When machine is scraping all electrical, electronic and plastic elements should be removed and remaining part should be scrapped as steel scrap. Electrical materials (wires) can be scrapped as copper scrap.

UNI-TROL®

Zakład Produkcyjny i Salon Sprzedaży

UNI – TROL Sp. z o.o.

ul. Estrady 56, 01 - 932 Warszawa, Polska
tel. (22) 817 94 22 / 834 90 13 / 834 90 14
fax (22) 817 94 22 / 834 90 13 / 834 90 14 w. 115
strona: www.unitrol.pl
e-mail: office@unitrol.com.pl, office@unitrol.pl

WYWAŻARKI DO KÓŁ I WYWAŻARKI SPECJALNE MONTAŻOWNICE DO KÓŁ PROSTOWARKI
OBRĘCZY WYPOSAŻENIE WARSZTATOWE

REGON: 008132994

NIP: PL5270205246

EORI: PL52702052460000

NR KONTABANKOWEGO: BZ WBK SA nr:

NUMER REJESTROWY: KRS 000011731

611090.1014.0000.0000.0301.4565

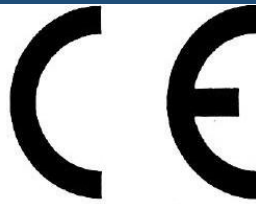

CE Conformity Declaration

in accordance with directives : 2006/42/EC, 2006/95/EC, 2004/108/EC

We: **Uni-Trol Sp. z o.o.**
Estrady 56,
01-932 Warsaw, Poland

declare, under our exclusive responsibility, that the product

Wheel balancer
model
MONOLITH
Serial number

mentioned in this declaration, complies with all relevant requirements of the Machinery Directive:

- **Directive 2006/42/EC (safety machines),**

applicable in the essential requirements and relevant conformity assessment procedures, as well as on the essential requirements of the following directives:

- **Directive 2006/95/EC (the low voltage);**

- **Directive 2004/108/EC (the electromagnetic compatibility).**

To verify the compliance with the applicable legal regulations harmonized standards and other normative documents have been consulted:

PN-EN ISO 12100:2012P

Safety of machinery -- General principles for design – Risk assessment and risk reduction

PN-EN 61000-6-3:2008P

Electromagnetic compatibility (EMC) -- Part 6-3: General standards -- Emission standard for environments: residential, commercial and light industrial

PN-EN 61000-6-4:2008P

Electromagnetic compatibility (EMC) -- Part 6-4: General standards -- Emission standard for industrial environments

PN-EN ISO 13857:2010P

Safety of machinery - Safety distances to prevent hazard zones being reached by upper and lower limbs

MONOLITH

PN-EN 349+A1:2010P

Safety of machinery - Minimum gaps to avoid crushing of parts of the human body

PN-EN 60204-1:2010P

Safety of machinery -- Electrical equipment of machines -- Part 1: General requirements

PN-EN 60745-1:2009/A11:2011E

Manual tools with electric drive - Safety of machinery -- Part 1: General requirements

PN-EN 60947-1:2010P

Low-voltage switchgear and controlgear-- Part 1: General requirements

PN-EN 61293:2000P

Marking of electrical equipment with ratings related to electrical supply -- Safety requirements

PN-EN ISO 11201:2012P

Acoustics -- Noise emitted by machinery and equipment -- Determination of emission sound pressure levels at a work station and at other specified positions in an essentially free field over a reflecting plane with negligible environmental corrections

PN-EN ISO11202:2012P

Acoustics -- Noise emitted by machinery and equipment -- Determination of emission sound pressure levels at a work station and at other specified positions applying approximate environmental corrections

PN-EN ISO 4871:2012P

Acoustics -- Declaration and verification of noise emission values of machinery and equipment

The technical documentation of this device, referred to in point 1 of Annex VII A of the Machinery Directive, is located in the headquarters Uni-trol Ltd. (address as above) and will be made available to the competent national authorities for at least 10 years after the last piece.

The person responsible for the preparation of the technical documentation of the product and introducing changes in it, is MSc. Gregory Tworek - Member of the Board.

This EC Declaration of Conformity will be kept by the manufacturer of the product for 10 years from the date of produce the last unit and will available for market supervisory authorities for verification.

MSc. Gregory Tworek - Member of the Board.

Warsaw, 21.10.2013

.....
Signature