

## 2451 L

2451 L is a wheel balancer with laser measuring arm entering wheel parameters and wheel guidance system directing the wheel to unbalance point. The system memorizes the data and shows precisely the weight position. The machine is equipped with ultrasonic sonar for contactless wheel width measurement and rim recognition system according to the entered parameters.

The completely new operating system based on two buttons and a wheel as a selection cursor makes the machine very intuitive to use.

- Automatic positioning lock
- Laser measuring arm
- Ultrasonic non-contact rim width acquisition
- Voice synthesizer
- ALU programmes
- 2 ALU programmes for motorbikes
- programme "hidden weight"
- optimization
- LCD monitor



## Technical Data

Rim diameter range:	10" - 30"
Rim width range:	2" - 15"
Maximum wheel weight	70 kg
Balancing accuracy	1 g
Power of the drive engine	80 W
Electric supply	230V / 50Hz
Weight	120 kg

## Distinctive features:

---

**Haweke SoftGrip with cylinder 40 mm  
and 3 cones 44-111,5 mm.**

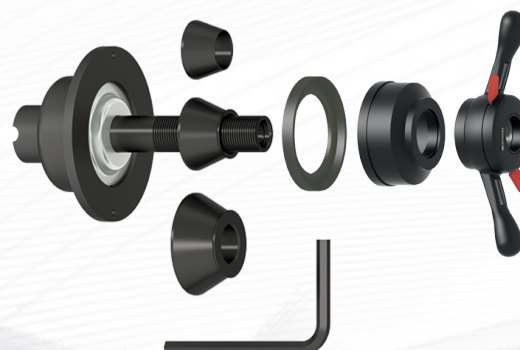

**Anvil.**



**Ergonomic tool tray.**



## Available Colors



Basic Colors



Custom Colors

## Additional Equipment

Index	Description	Photo
DO-5P	Flange plate 5-bolts	
150400049	Cone 95-132 mm Ø40	
04.04.008.40	Cone 125-145 mm Ø40	
06.04.009.40	Cone 145-165 mm Ø40	

Index	Description	Photo
150400043	Cone 122-174 mm Ø40	
190400018	Distance spacer for shaft Ø40	
W-U-5AH	Motorcycle wheel adaptor	
PPK-2	Wheel lift PPK-1 for wheel balancer	

Index	Description	Photo
T-CĘG-001	Wheel Balancing Weight Plier& Hammer Tool	
WT-2065-1	Wheel Weight Scraper Tool	