

MONOLITH S

Monolith configuration:

- Automatic protection hood
- Automatic electric-brake at unbalance position
- Calibration
- Voice synthesizer
- Laser adjuster
- Alu programmes
- Automatic positioning lock
- Contactless wheel parameters measurement
- Optimization
- USG rim width measurement
- Programme 3P - "hidden weight"
- Touchscreen LED monitor
- Print to file
- Operator's memory
- Automatic diameter, width and offset measurement
- Unbalance recalculating
- Manual clamp Haweka Progrid with 3 cone



Technical Data

Rim diameter range:	10" - 30"
Rim width range:	2" - 15"
Maximum wheel weight	80 kg
Balancing accuracy	1 g
Imbalance position indicator accuracy	0.45°
Measuring speed	140 obr/min
Power of the drive engine	80 W
Electric supply	230V / 50 Hz
Pneumatic power supply	8 - 10 bar
Dimensions	980/1250/1490
Weight	120 kg

Distinctive features:

The balancer is equipped with a patented system for inputting wheel parameters based on a real image from a camera. Additionally, for more precise determination of the correction location, the balancer features a laser indicator that accurately points to the spot where the weight should be attached.

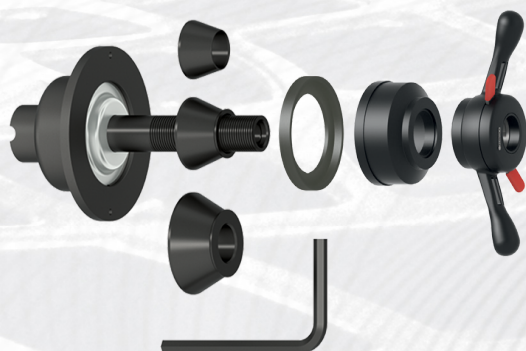
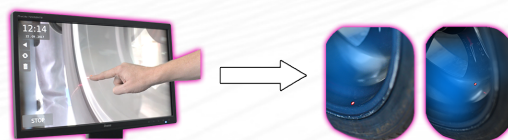

The balancer is equipped with a modern quick-release clamp from HAWEKA, which significantly shortens the time and facilitates secure mounting of the wheel on the balancer's spindle without the risk of off-center attachment.

United States of America



(12) **United States Patent**
Roguski et al.

(10) **Patent No.:** US 10,281,355 B2
(45) **Date of Patent:** May 7, 2019

(54) **METHOD AND SYSTEM FOR THE OPTICAL DETERMINATION OF CORRECTION PLANES IN ROTATING ELEMENTS**

FOREIGN PATENT DOCUMENTS

EP 0724144 7/1996
EP 1398611 3/2004
WO 98/10261 3/1998

(71) Applicant: **UNIT S.C. Wieslaw Roguski, Jan Tworek, Zaborow (PL)**

(72) Inventors: **Wieslaw Albin Roguski, Lomianki (PL); Wojciech Wieslaw Roguski, Lomianki (PL); Jan Tworek, Warsaw (PL)**

OTHER PUBLICATIONS

EP Search Report for EP16185127, completed Jan. 17, 2017.
PPO Search Report for P413757, completed Sep. 5, 2016.

(73) Assignee: **UNIT S.C. WIESLAW ROGUSKI, JAN TWOREK, Warsaw (PL)**

Primary Examiner—Walter L Lindsay, Jr.
Assistant Examiner—Philipmarcus T Fadul
(74) Attorney, Agent, or Firm—Barnes & Thornburg LLP

(*) Notice: Subject to any disclaimer, the term of this patent is extended or adjusted under 35 U.S.C. 154(b) by 279 days.

(57) **ABSTRACT**

The subject matter of the present invention relates to a system for the optical determination of correction planes in rotating elements, used in the process of balancing, in particular in diagnostic devices equipped with a system which has at least one video camera (K), at least one line projector (RL), a monitor screen (M) and a computer (P) which controls individual component elements of the system, wherein the video camera (K) cooperates with the line projector (RL) while projecting a view of the rotating element (EW) on the monitor screen (M) together with an image of a line (L) projected by means of the line projector (RL).

The subject matter of the present invention also relates to a method for determining correction planes which consists in defining an area of measurement space; is defined on the basis of a virtual rotating element (EW) by placing a rotating element (EW) on the shaft of a diagnostic device (PM) onto which line (L) is projected by means of line projector (RL), and subsequently image of the rotating element (EW) is transmitted by means of the video camera (K) to the monitor screen (M) together with an image of the projected line (L), and thus the image of the lines obtained which shows a change in the values of the radius r_1 from the axis of the shaft of the diagnostic device (PM) and the angle of distance α of the rotating element (EW) from the diagnostic device (PM) in the defined area of measurement space.

(21) Appl. No.: 15/242,957

(22) Filed: Aug. 22, 2016

(65) Prior Publication Data
US 2017/015040 A1 Mar. 2, 2017

(51) Int. Cl.
G01M 1/28 (2006.01)
G01M 1/16 (2006.01)
(Continued)

(52) U.S. Cl.
CPC G01M 1/16 (2013.01); G01M 1/225 (2013.01); G01M 1/28 (2013.01); G01M 1/381 (2013.01); G01M 7/181 (2013.01)

(58) Field of Classification Search
CPC G01M 1/16
(Continued)

(56) References Cited
U.S. PATENT DOCUMENTS
5,827,964 A 10/1998 Douine et al.
6,484,574 B1 11/2002 Douglas et al.
(Continued)

6 Claims, 6 Drawing Sheets

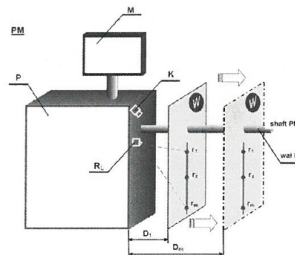

Andres Ibarra
DIRECTOR OF THE UNITED STATES PATENT AND TRADEMARK OFFICE

Available Colors



Basic Colors



Custom Colors

Additional Equipment

Index	Description	Photo
DO-5P	Flange plate 5-bolts	
150400049	Cone 95-132 mm Ø40	
06.04.017.40	Cone 110-125 mm Ø40	
04.04.008.40	Cone 125-145 mm Ø40	

Index	Description	Photo
150400043	Cone 122-174 mm Ø40	
190400018	Distance spacer for shaft Ø40	
PPK-2	Wheel lift PPK-1 for wheel balancer	
T-CĘG-001	Wheel Balancing Weight Plier & Hammer Tool	

Index	Description	Photo
WT-2065-1	Wheel Weight Scraper Tool	