

MANAGER



Dane techniczne

| | |
|-----------------------------|------------------|
| Outside clamping capacity | 12" - 24" |
| Inside clamping capacity | 14" - 26" |
| Max. wheel width | 15" |
| Max. wheel diameter | 1150 mm |
| Bead-breaker pressure force | 3500 kg |
| Pneumatic supply | 8 - 10 bar |
| Table rotation speed | 8 / 16 obr./min. |
| Electric supply | 3 x 400V / 50 Hz |
| Motor power | 1,3 kW / 1,8 kW |
| Weight | 380 kg |
| Wheel clamp | Pneumatyczny |
| Dimensions | 1430/860/1550 |

Automatic tyre-changer MANAGER 12 " - 26"

For rims from 12 " to 26"
Automatic column tilting
Helper PLUS for high performance tyres
Two speeds (8-16 rpm)
Automatic bead-breaker
Additional shelves with inflator
Automatic Leverless finger - (optional)
Inflator for tubeless tyres TI - (optional)
New steering pedal system
Modern look
New locking system
Working pressure 8-10 Bar



Automatically tilting column Automatic bead-breaker





Assistant PLUS

Additional shelves with inflator



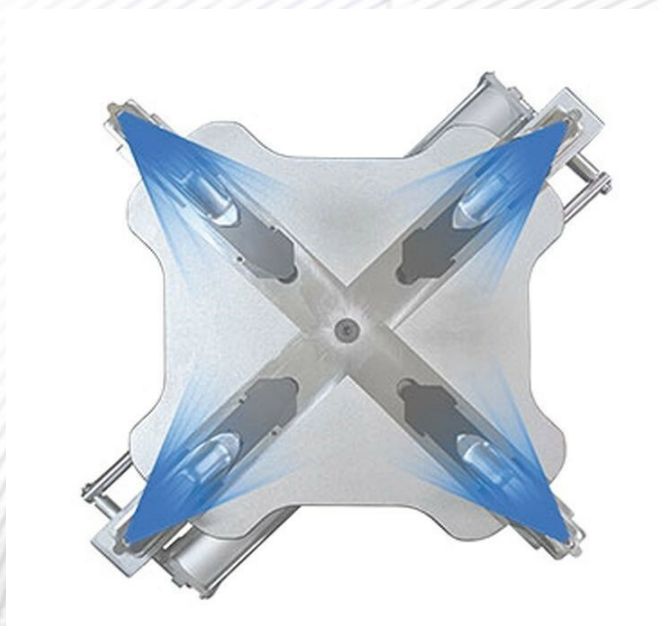

Two speeds (8-16 rpm) Inflator TI for tubeless tyres



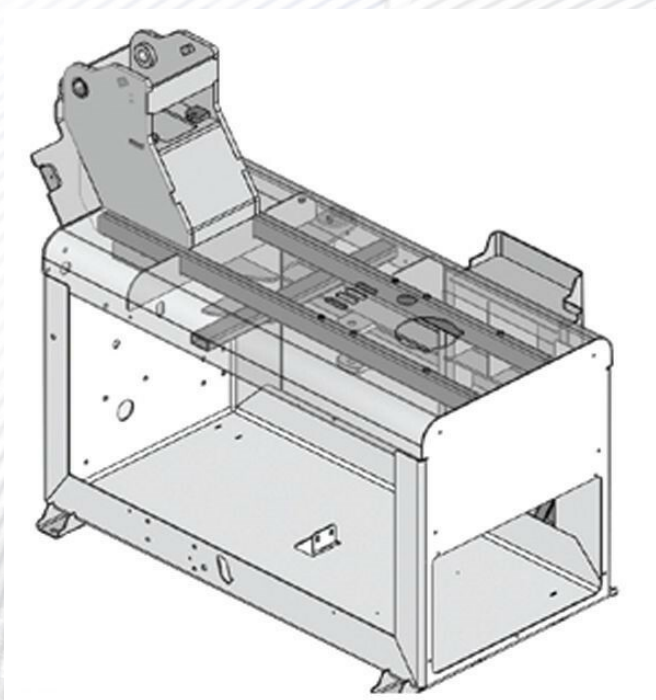

Automatic Leverless finger Reinforced structure

