

MANAGER

The MANAGER tire changer is designed for handling large wheels equipped with 'Run-flat' and low-profile tires. The reinforced construction of the cabinet and column ensures rigidity, even when working with large tires. The high force and range of the bead breaker provide safe operation. The machine is equipped with the PLUS adapter, which includes a pneumatically locked roller, disc, and pressure clamp.



Technical Data

Outside clamping capacity	12" - 24"
Inside clamping capacity	14" - 26"
Max. wheel width	15"
Max. wheel diameter	1150 mm
Bead-breaker pressure force	3500 kg
Pneumatic supply	8 - 10 bar
Table rotation speed	8 / 16 obr./min.
Electric supply	3 x 400V / 50 Hz
Motor power	1,3 kW / 1,8 kW
Weight	380 kg
Wheel clamp	Pneumatyczny
Dimensions	1430/860/1550

Automatic Manager Tire Changer

- Automatic column tilting
- PLUS adapter for high-performance tires
- Two speeds (8-16 rpm)
- New generation automatic bead breaker
- Additional shelves with inflator for tire inflation
- New pedal control system
- Modern design
- New locking system
- Operating pressure 8-10 Bar

Distinctive features:

Reinforced column construction with automatic rear tilt





Bead breaker with high force and a wide range of supported wheels

Reinforced PLUS adapter equipped with a pneumatically locked roller, a disc for breaking the lower bead, and an additional pantograph pressure clamp. At the bottom, there is a holder for a bucket with paste.



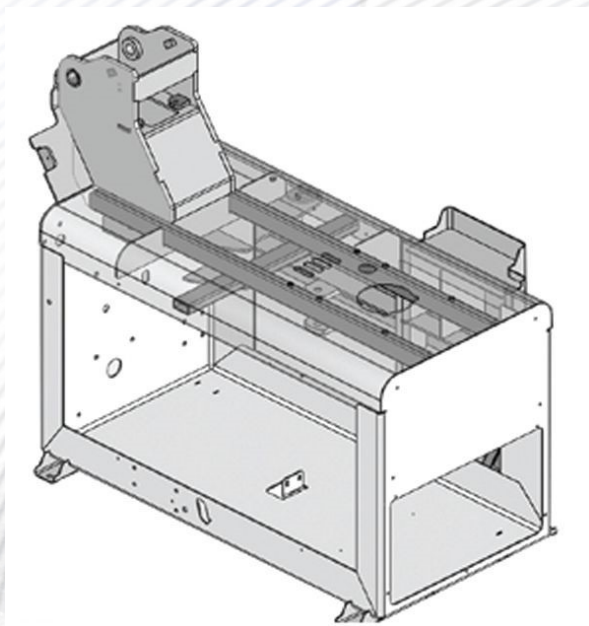

The ergonomically designed reinforced machine structure allows for long, reliable operation of key components.

The wheel inflation system is controlled by a foot pedal, with additional shelves for valves and accessories.





The three-phase table drive has two rotational speeds

Standard equipment:

- Inflation system with a pressure gauge
- Mounting lever
- Adapters for low-profile and run-flat tires
- Covers for clamps for aluminum rims
- Roller guard

