

JANKA K 2B

Automatic tyre-changer for car and van wheels including RUNFLAT tyres. The column and the arm move and blocked pneumatically. The robust construction and independent pneumatic arm saves operator time and effort. The tyres and wheels are handled with little effort and with the highest accuracy without the risk of tyre or rim damage. It also enables handling of aluminum rim wheels without any damage of delicate rim surface. The table of two clamping ranges till 23 " or 26".

- strong and solid design
- helper - powerful pneumatic bead assist device
- self-centering four jaws turntable
- tyre inflating gun with manometer
- set of jaw protectors for aluminum rims
- head roll guard
- tyre lever
- two-speed motor 7/14 rpm

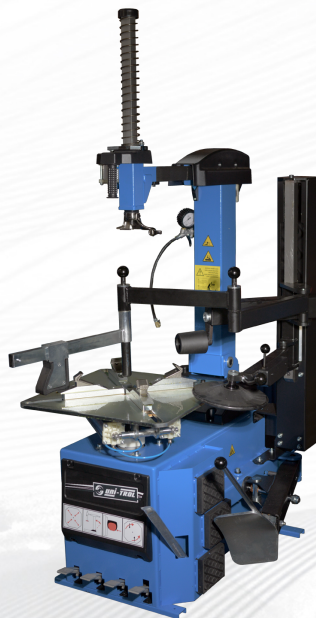

Dane techniczne

Outside clamping capacity	10" - 26"
Max. wheel width	15"
Max. wheel diameter	1070 mm
Bead-breaker pressure force	2800 kg
Pneumatic supply	8 - 10 bar
Table rotation speed	7/14 obr./min.
Electric supply	3 x 400V / 50 Hz
Motor power	0,75 kW
Weight	250 kg
Wheel clamp	Pneumatyczny
Dimensions	850/1520/900

Distinctive features:

Reinforced horizontal slide

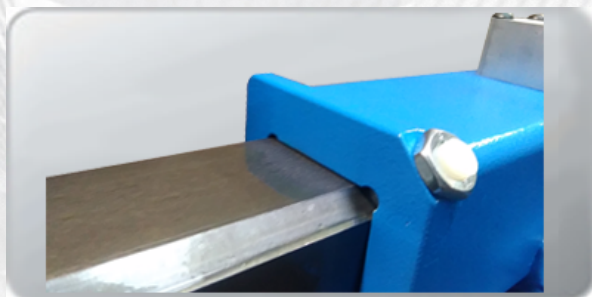

Grub screws to eliminate the lateral plays on slide during machine operation

Column axle pivot and adjusting pads make machine more rigid and durable

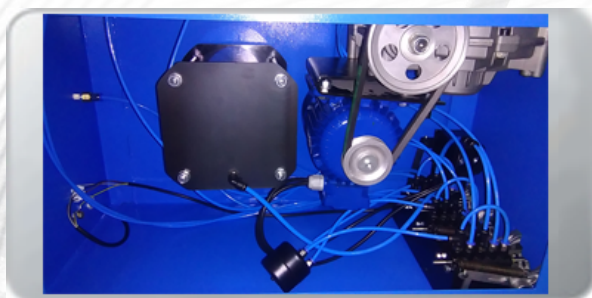
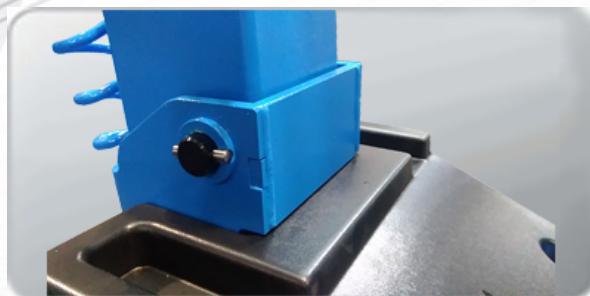

**Ergonomic inside provides long and failureless functioning of the main components.
Big and precise cylinder**

Wheel inflation system controlled by a foot pedal as optional equipment



Clamping range:

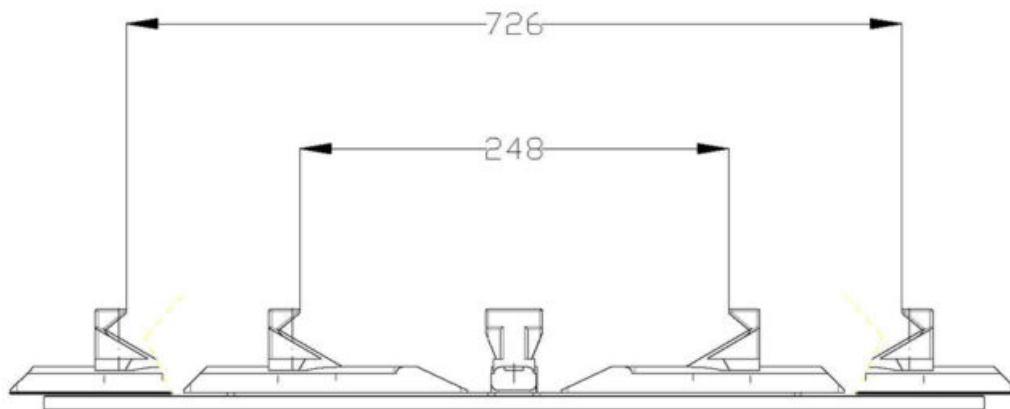

Standard equipment:

- Inflation gun with a pressure gauge
- Mounting lever
- Adapters for low-profile and run-flat tires
- Covers for clamps for aluminum rims
- Roller guard

Dostępne kolory



Kolory podstawowe



Kolory na zamówienie

