

## S20 MOTO

**Tyre-changer S20 MOTO** for motorcycle, scooter and quad tyres. For rims of clamping range 5"-23 ". The biggest advantage of this model is the vertical bead-breaker that removes the tyre safely without dismantling the brake discs. Thanks to the compact housing and the arm tilted to the side the machine does not require much space in the workshop. The left side pedals provide much better work comfort.



### Dane techniczne

Inside clamping capacity	5" - 23"
Max. wheel diameter	1020 mm
Max. wheel width	14,5"
Table rotation speed	8 obr/min
Bead-breaker pressure force	860 kg
Power of the drive engine	0,75 kW
Weight	208 kg
Electric supply	3x400V / 50 Hz
Pneumatic supply	8-10 bar
Dimensions	1100/1160/2050

## Distinctive features:

---

The tyre changer is equipped with a **DOUBLE ACTING BEAD BREAKING CYLINDER**, that enables the operator to control the activities while operating by standing comfortably. The wheel support can be adjusted in three different positions in order to operate on every rim model and size, such as motorbikes, go-kart, garden equipment, mopeds and quads. The **WHEEL SUPPORT** is **EXTRACTABLE** and can be **HORIZONTALLY ADJUSTED**. It enables the operator to operate in safety and keeping the breaking operations under control



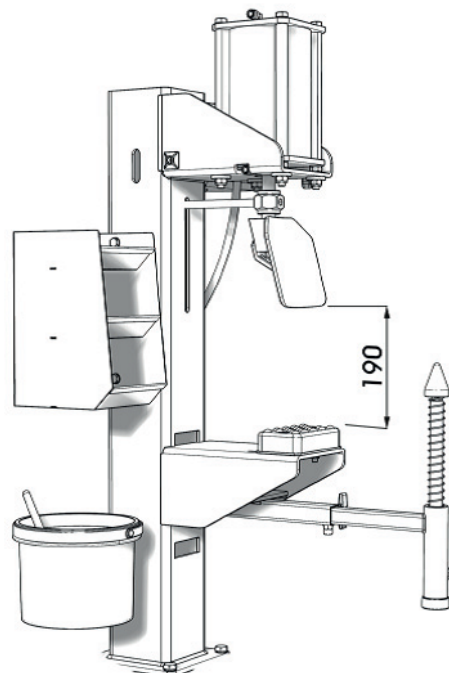
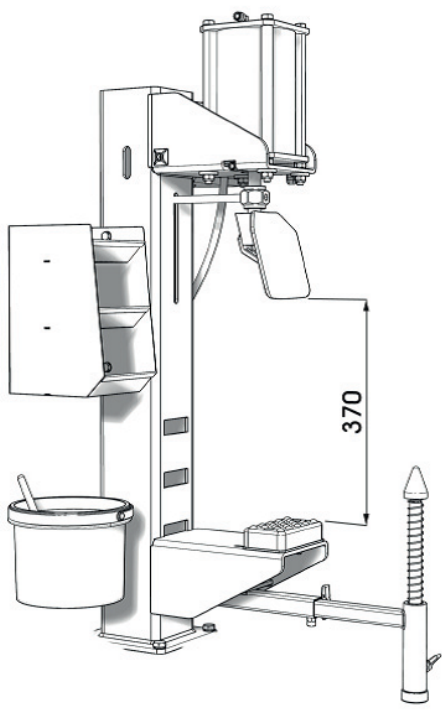
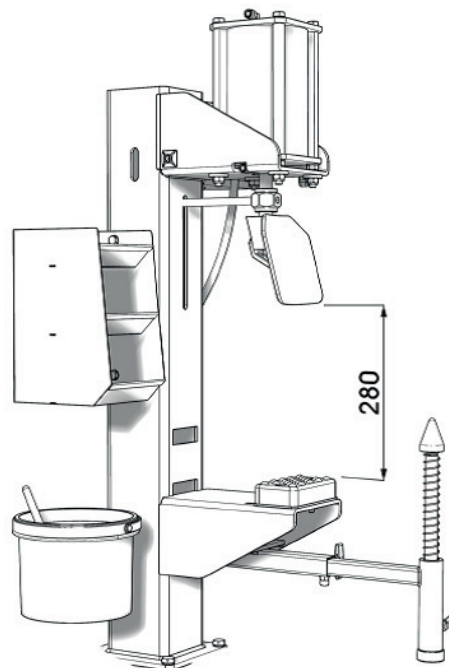
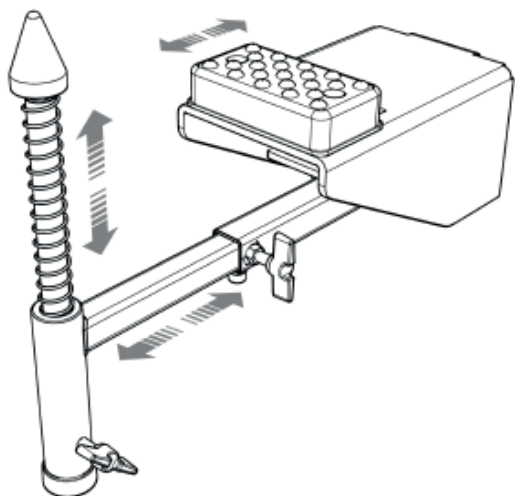



The SELF CENTERING TURNTABLE is equipped with curved guiding rods, that keep the clamping force constant as the rim size changes. It is possible to operate on different rims size (from 5" to 23") by adjusting the clamps.

## Standard equipment:

- Bead Blade protection
- Quads wheel adapters kit
- Bead lever
- Tape-a-weight removal tool
- Extractable and adjustable support for bead breaking arm
- Grease support

## Clamping range:

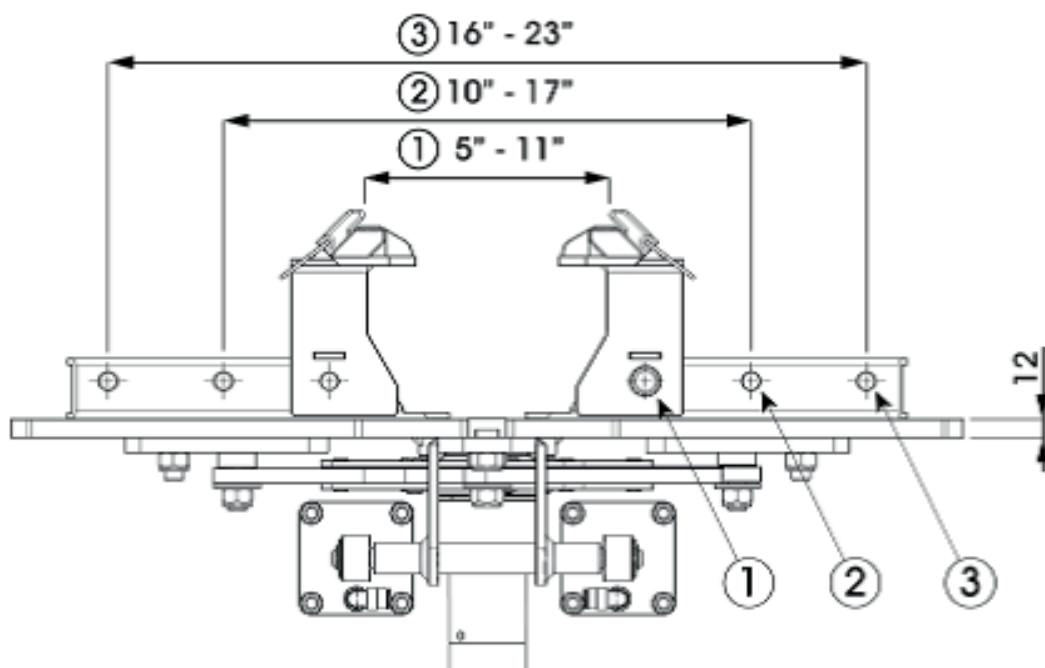

## Extra options:

---

The **FOOT CONTROLLED INFLATING DEVICE** is positioned in a comfortable position for reading and use. (OPTION).

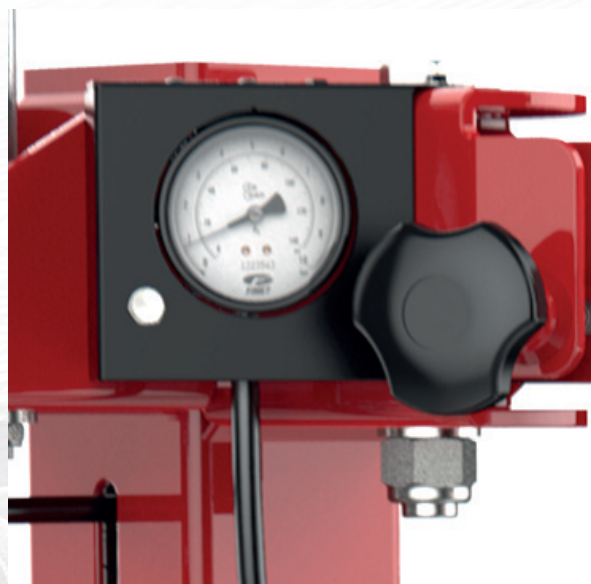



The QUICK-CHANGE TOOL HUB KIT in composed by two tool holder hubs and a mounting tool for mopeds wheels. (OPTION).

The TOOL TRAY KIT could be positioned rear the vertical column.  
(OPTION)



## Dostępne kolory



Kolory podstawowe

